



Project co-financed by the European Regional Development Fund

Nondestructive material inspections using brilliant quasi-monoenergetic gamma beams at ELI-NP

**Violeta Iancu¹, G. Suliman¹, G. V. Turturica¹, E. Hermann², M. Iovea², D. L.
Balabanski¹, H. Ohgaki³, C. A. Ur¹**

¹Extreme Light Infrastructure-Nuclear Physics, IFIN-HH, Romania

²ACCENT PRO 2000, s.r.l., Bucharest, Romania

³The Institute for Advanced Energy Kyoto University, Uji, Kyoto 6110011, Japan

Outline

- *Extreme Light Infrastructure – Nuclear Physics*
- *Gamma beam system – high brilliance quasi-monoenergetic gamma beams*
- *Nondestructive material inspections:*
 - *Nuclear resonance fluorescence*
 - *Gamma ray attenuation*

Extreme Light Infrastructure – Nuclear Physics

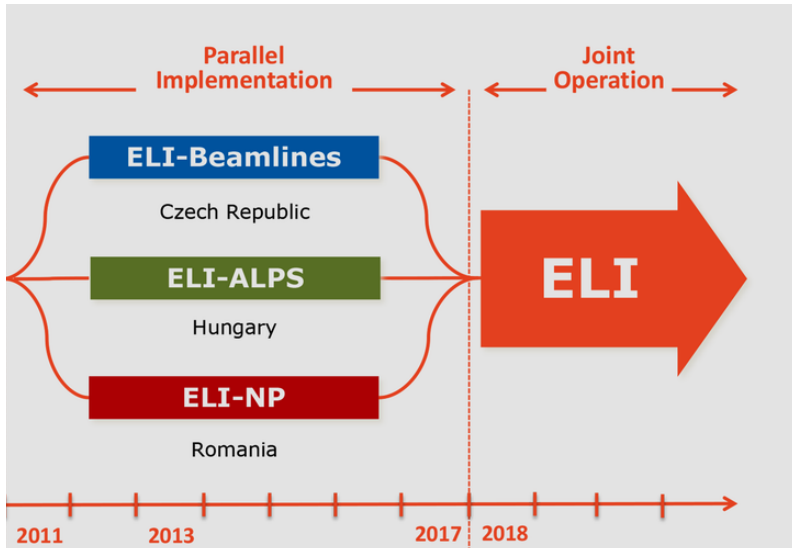

- **High Power Laser System (HPLS)** - 2×10 PW with $10^{23} - 10^{24}$ W/cm²
– *contracted by Thales Optronique SA*
- **Gamma Beam System (GBS)** - high intensity, tunable energy from 0.2 MeV to 19.5 MeV – *contracted by EuroGammaS Consortium led by INFN Rome*

The ELI-NP gamma beams

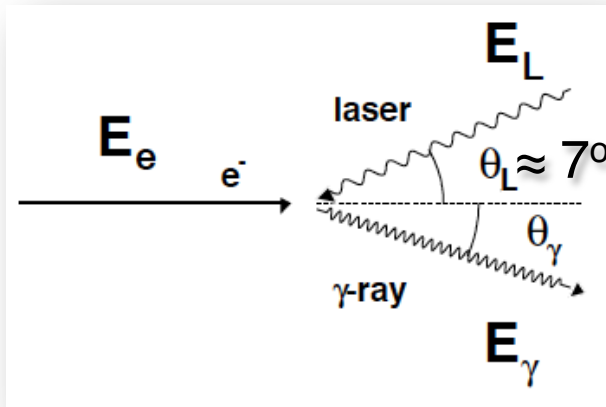

gamma-rays from Inverse Compton Scattering

photon scattering on ultra relativistic electrons ($\gamma \gg 1$)

'Photon accelerator'

$$E_\gamma = 2\gamma_e^2 \frac{1 + \cos\theta_L}{1 + (\gamma_e\theta_\gamma)^2 + a_0^2 + \frac{4\gamma_e E_L}{mc^2}} E_L$$

- **maximum upshift:** head-on collision ($\theta_L=0$) & backscattering ($\theta_\gamma=0$)

ELI-NP Solution

- ICS of laser pulses on relativistic electron pulses
 - high intensity / small emittance e^- beam from a warm LINAC
 - very brilliant high rep./rate int. laser
 - small collision volume

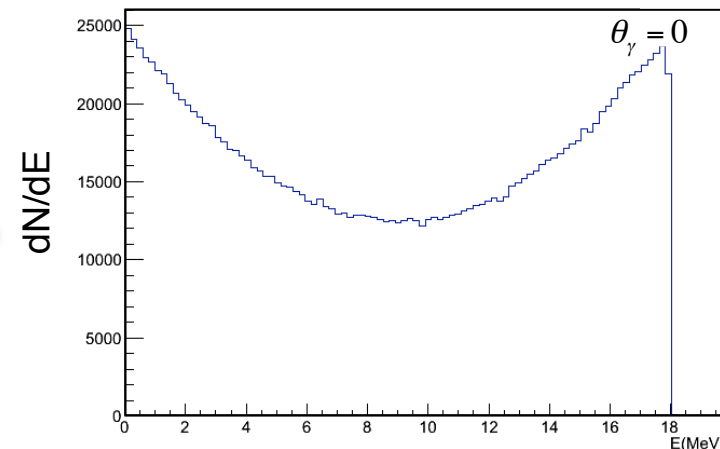

$$E_\gamma \approx 4\gamma_e^2 E_L$$

The ELI-NP gamma beams

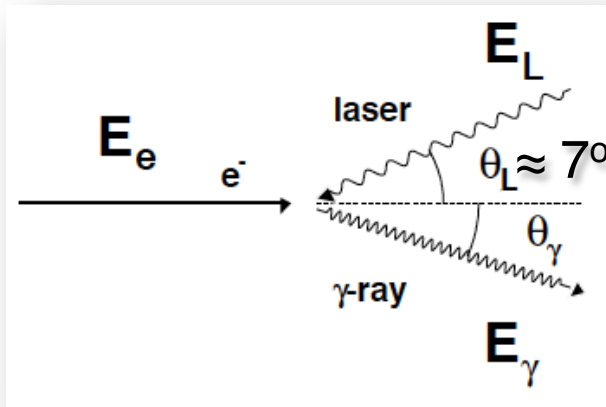

gamma-rays from Inverse Compton Scattering

photon scattering on ultra relativistic electrons ($g \gg 1$)

'Photon accelerator'

$$E_\gamma = 2\gamma_e^2 \frac{1 + \cos \theta_L}{1 + (\gamma_e \theta_\gamma)^2 + a_0^2 + \frac{4\gamma_e E_L}{mc^2}} E_L$$

- maximum upshift: head-on collision ($\theta_L=0$) & backscattering ($\theta_\gamma=0$)

ELI-NP Solution

- ICS of laser pulses on relativistic electron pulses
 - high intensity / small emittance e^- beam from a warm LINAC
 - very brilliant high rep./rate int. laser
 - small collision volume

Energy of photons after collimator

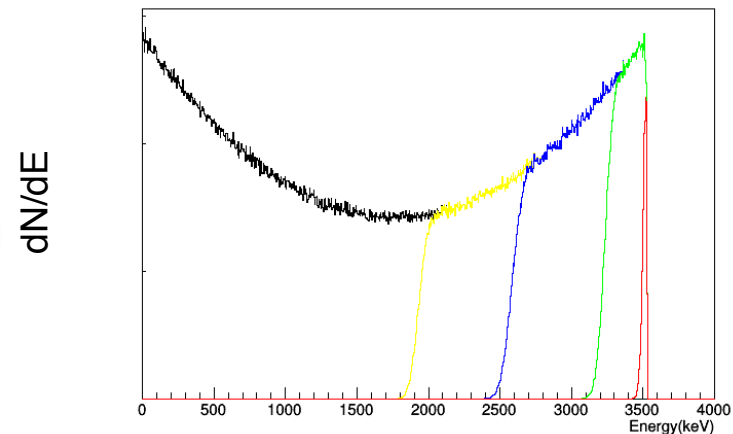

$$E_\gamma \approx 4\gamma_e^2 E_L$$

Main Components of the GBS

1) Warm electron RF Linac

- two acceleration stages (300 MeV and 720 MeV)

2) High average power, high quality J-class 100 Hz psec Collision Laser

- two lasers (one for low- E_γ and both for high- E_γ)

3) Laser circulation with μm and μrad and sub-psec alignment/synchronization (metrology/interferometry optical cavities)

- two interaction points – low- $E_\gamma < 3.5 \text{ MeV}$ and high- $E_\gamma < 19.5 \text{ MeV}$

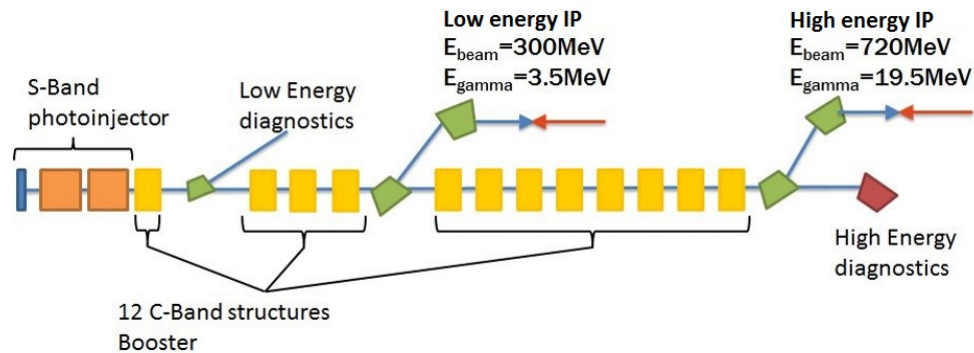

Main Components of the GBS

1) Warm electron RF Linac

- two acceleration stages (300 MeV and 720 MeV)

2) High average power, high quality J-class 100 Hz psec Collision Laser

- two lasers (one for low- E_γ and both for high- E_γ)

3) Laser circulation with μm and μrad and sub-psec alignment/synchronization (metrology/interferometry optical cavities)

- two interaction points – low- $E_\gamma < 3.5 \text{ MeV}$ and high- $E_\gamma < 19.5 \text{ MeV}$

4) Gamma beam collimation to obtain bandwidths $< 5 \times 10^{-3}$ and gamma beam characterization

GBS modeling



Gamma beams parameters

Parameter [units]	Value
Photon energy [MeV]	0.2 – 19.5
Spectral density [ph/s/eV]	$> 10^4$
Bandwidth	$< 0.5 \%$
# photons / shot FWHM bdw.	$1.0 - 4.0 \cdot 10^5$
# photons/sec FWHM bdw.	$2.0 - 8.0 \cdot 10^8$
Source rms size [μm]	10 – 30
Source rms divergence [μrad]	25 – 250
Peak brill. [$N_{\text{ph}}/\text{sec}\cdot\text{mm}^2\text{mrad}^2\cdot 0.1\%$]	$10^{22} - 10^{24}$
Radiation pulse length [ps]	0.7 – 1.5
Linear polarization	$> 97 \%$
Macro repetition rate [Hz]	100
# of pulses per macropulse	> 31
Pulse-to-pulse separation [ns]	16

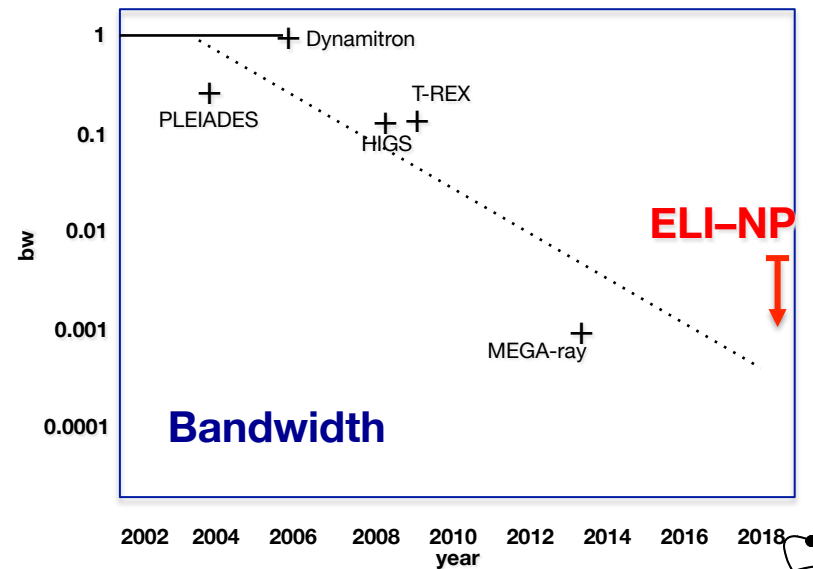
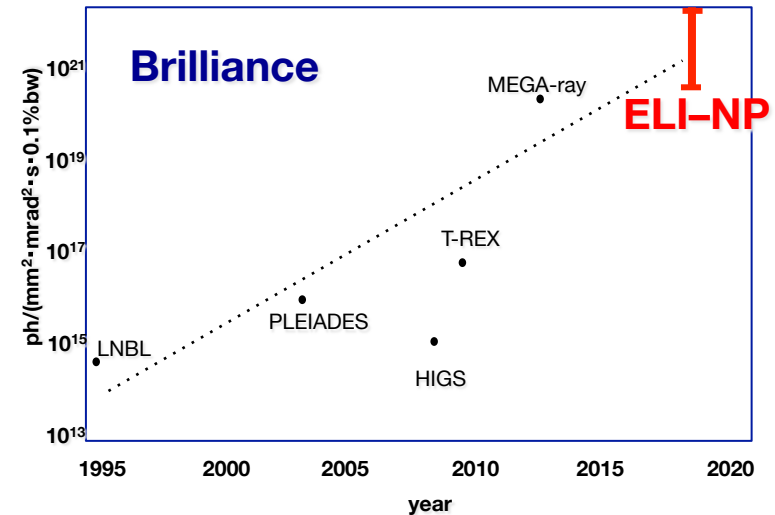

GBS Applications: Non-destructive inspections

Aim: Use the gamma beam as a probe to study the structural properties and the elemental composition of industrial objects

- A. Active interrogation – Nuclear resonance fluorescence**
- B. High resolution radiography and tomography imaging**

**NRF + CT:
Elemental/
isotopic maps**

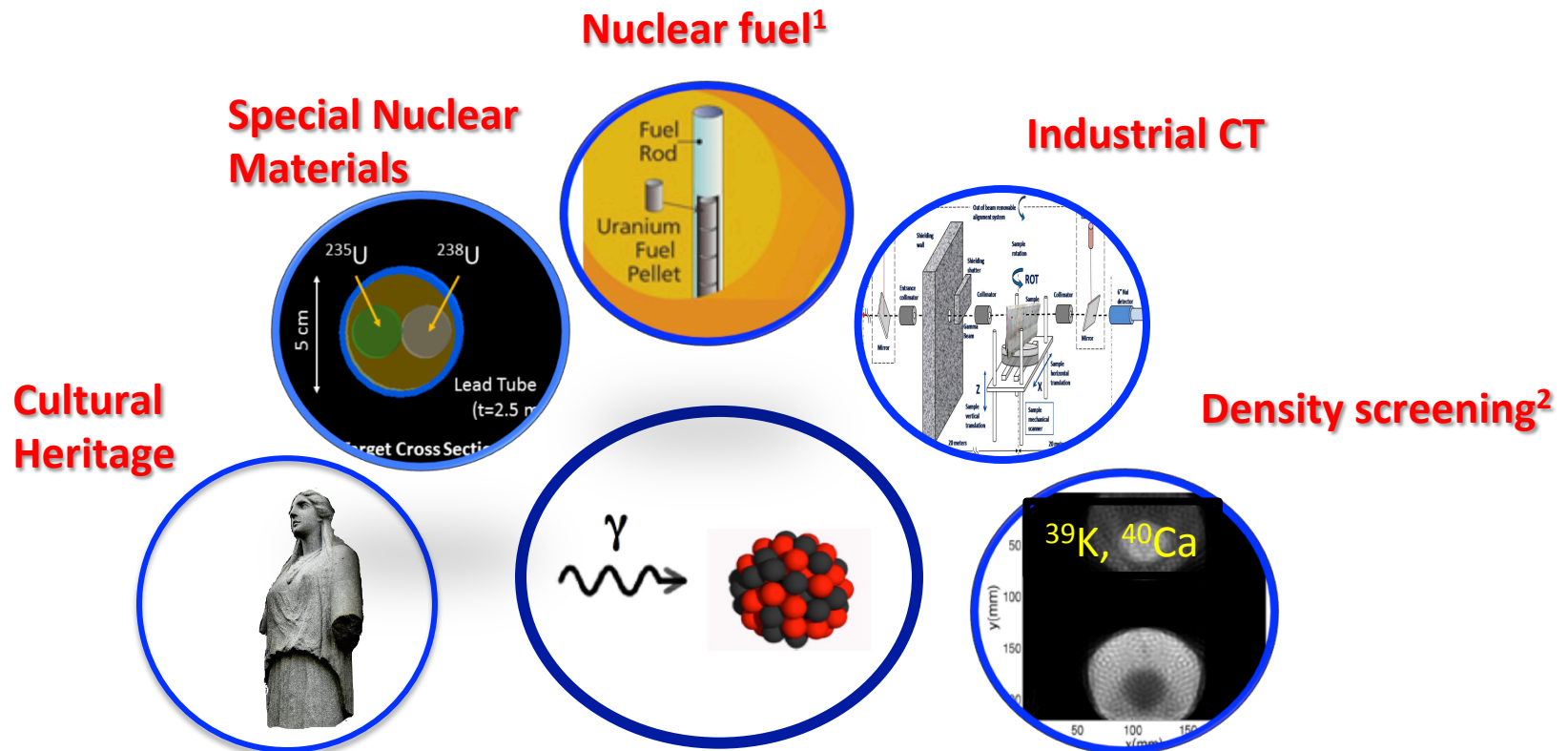

¹nrc.gov; ²M. N. Lakshmanan et al. Nucl. IEEE Trans. Med Imag. 33, 546 (2014)

Active interrogation – Nuclear resonance fluorescence

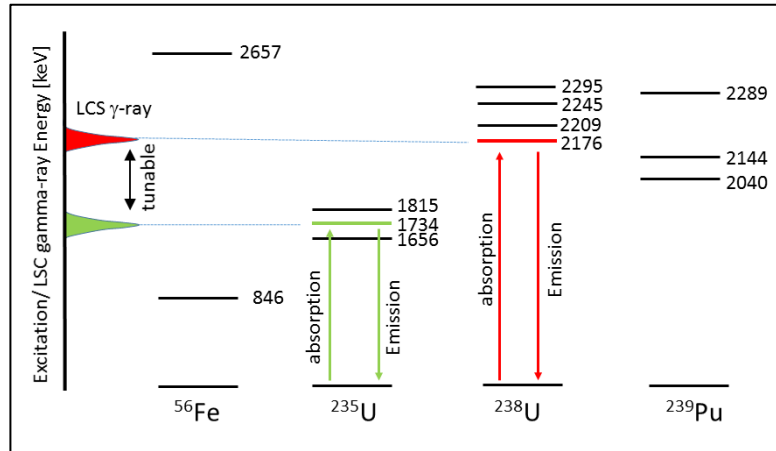

Active interrogation – Nuclear resonance fluorescence

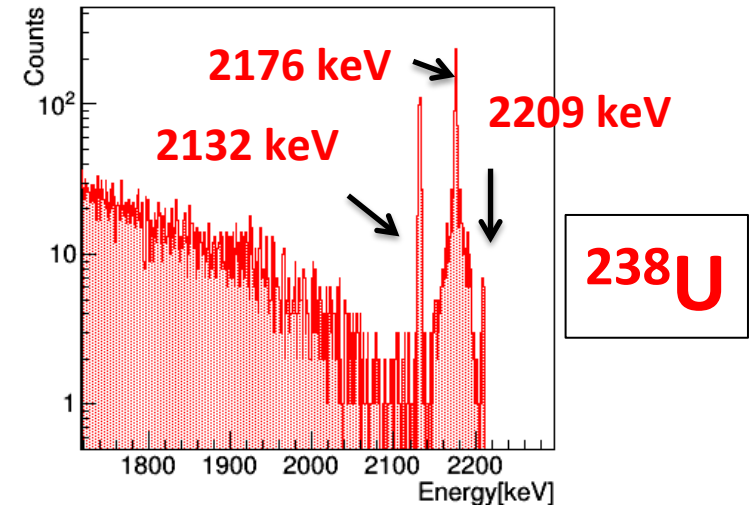
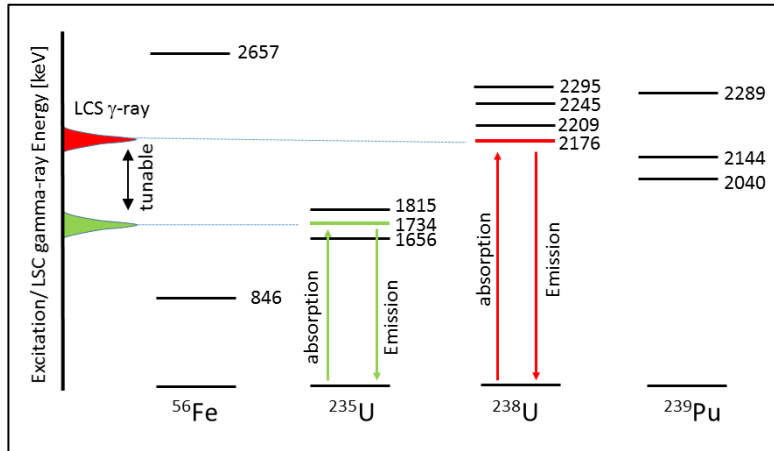

- Identification of elemental composition
- Noninvasive, nondestructive

Previous experimental demonstration

Detecting shielded U

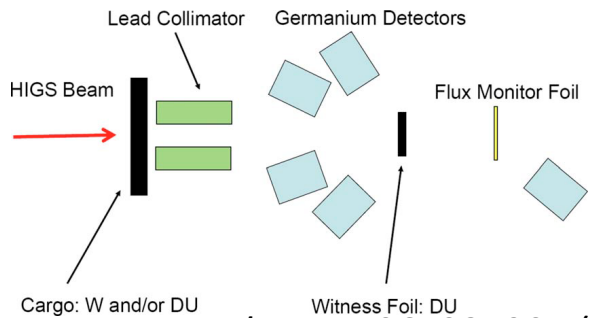

C. A. Hagmann *et al.* JAP. 106, 084901 (2009)

1-d imaging of Pb inside a iron box

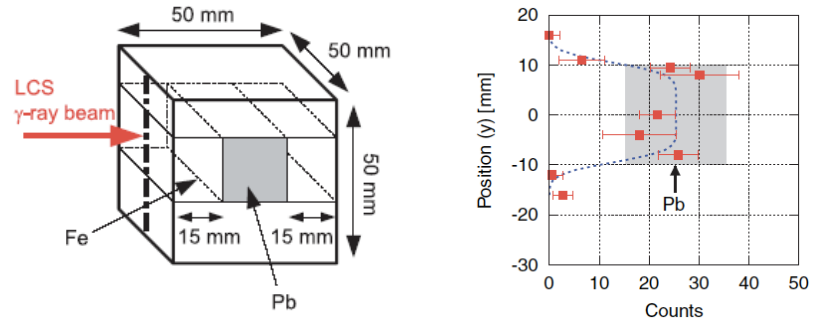

N. Kikuzawa, Appl Phys Express 2, 036502 (2009)

Spent fuel storage canister

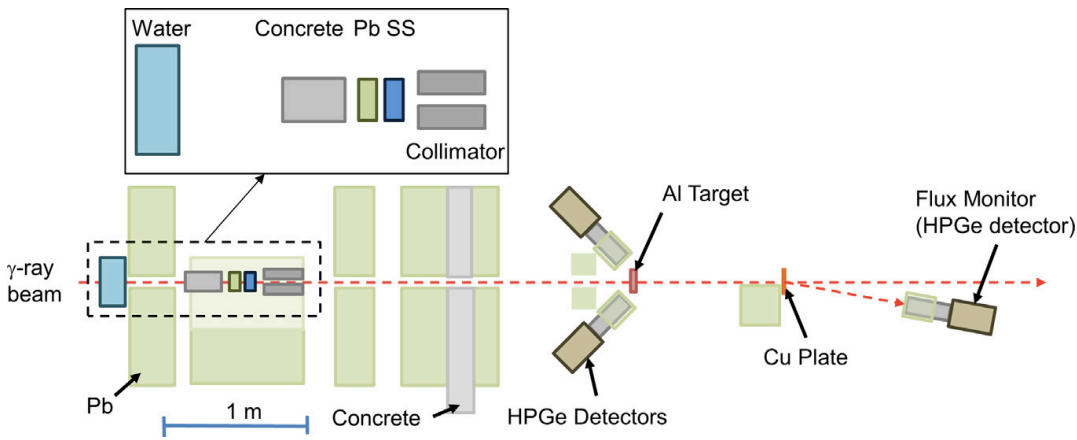

C.T. Angell *et al.* NIM B 347 (2015) 11–19

Material identification

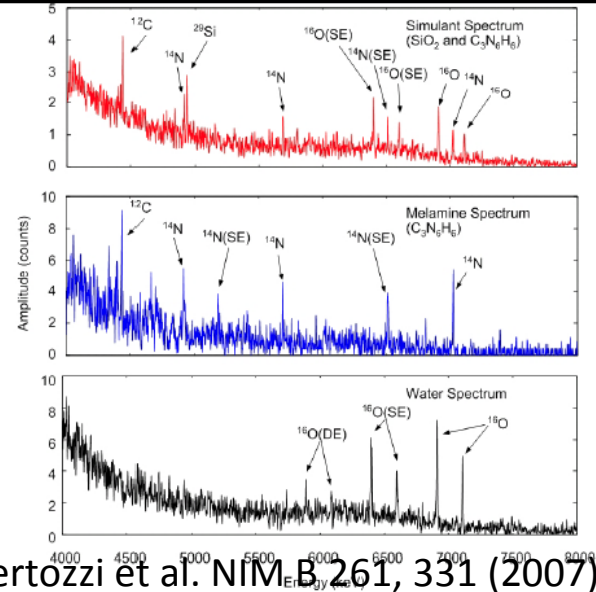

Bertozzi *et al.* NIM B 261, 331 (2007)

Active interrogation measurements at ELI-NP

- ✓ High intensity gamma beam – reduced measurement time
up to 4×10^8 photons/s – 10^5 photons/pulse
- ✓ Small bandwidth – high resolution at resonance level
 $\Delta E/E = 0.5\%$ – @ 2 MeV – 10 keV bandwidth
- ✓ Tunable energy – selectivity
0.2 MeV – 19.5 MeV
- ✓ High efficiency detector array - high statistics/low uncertainties
ELI-NP Array of Detectors – ELIADE array

ELI-NP Array of Detectors: ELIADE

- 8 segmented clover HPGe detectors placed on two rings (90° and 135°)

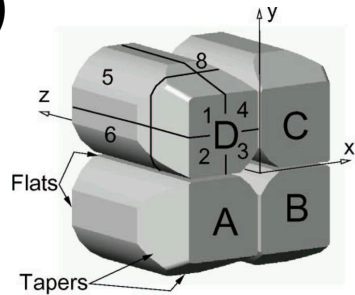

- 4 large volume LaBr₃ in between on the 90° ring

Status:

- *Detectors ready*
- *The design of the mechanical structure is done and will be sent for execution soon*

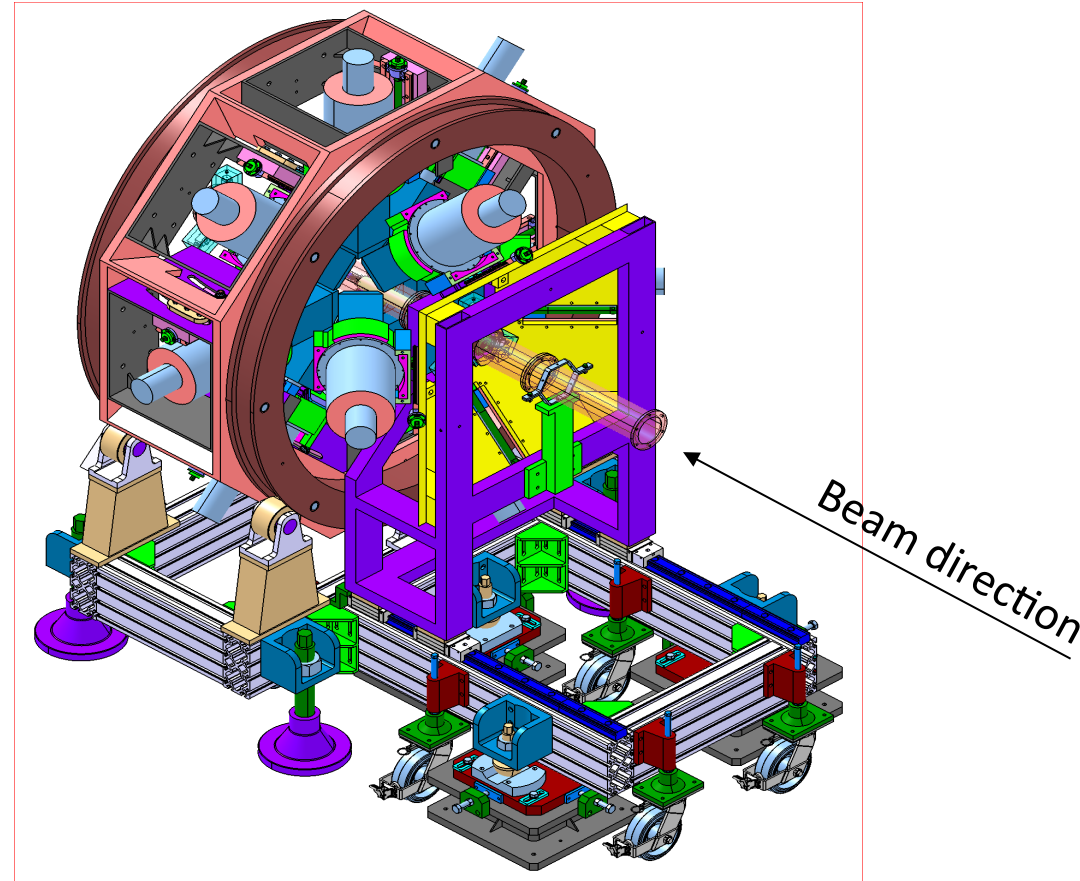

courtesy of C. Petcu ELI-NP

ELI-NP Array of Detectors: ELIADE

GEANT4 Monte Carlo simulations for the array optimization and background mitigation

Background radiation in the detectors

- Compton scattering of the beam

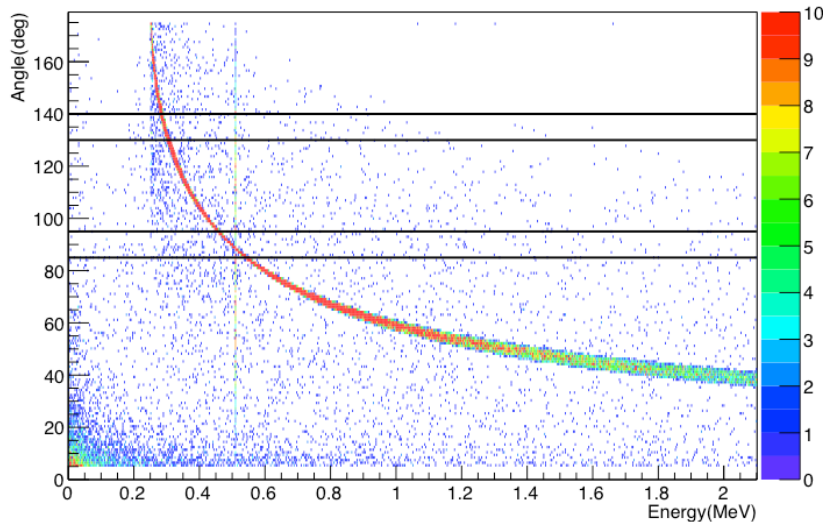

- **511 keV from positrons annihilation**

- segmented detectors to allow for simultaneous detection of many “events”
- thick lead absorbers to remove the background

1. Schumacher et al., Nucl. Phys. A 346, 418 (1980).

ELI-NP Array of Detectors: ELIADE

GEANT4 Monte Carlo simulations for the array optimization and background mitigation

Background radiation in the detectors

- Compton scattering of the beam

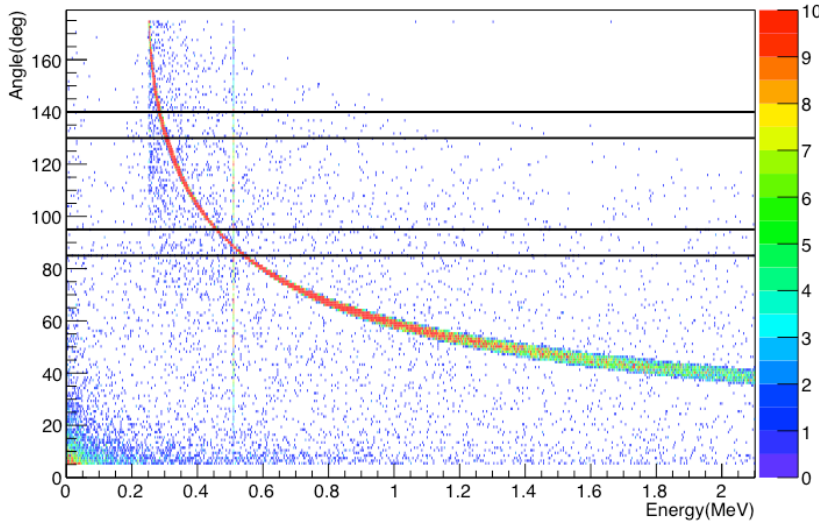

- 511 keV from positrons annihilation

- segmented detectors to allow for simultaneous detection of many “events”
- thick lead absorbers to remove the background

- Elastic scattering – Rayleigh, Delbrück, Thomson ¹

M. Schumacher et al. / Delbrück scattering

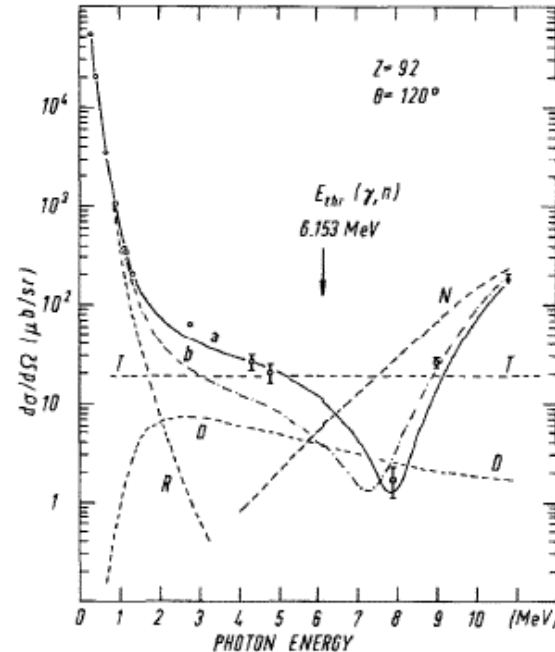

$$R_{\text{NRF}} \sim 1000 R_{\text{background}} \text{ for small } \sigma \text{ (for a HPGe)}$$

1. Schumacher et al., Nucl. Phys. A 346, 418 (1980).

ELI-NP Array of Detectors: ELIADE

GEANT4 Monte Carlo simulations for the array optimization and background mitigation

Background radiation in the detectors

- Compton scattering of the beam

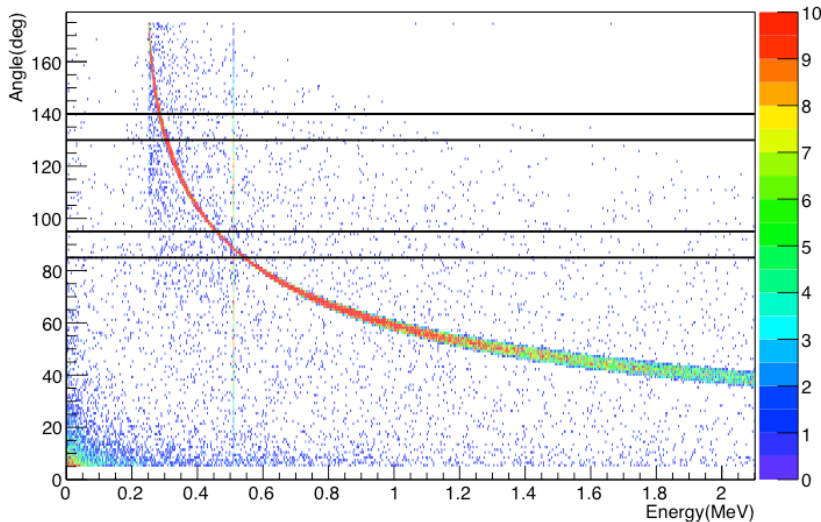

- Elastic scattering – Rayleigh, Delbruck, Thomson ¹

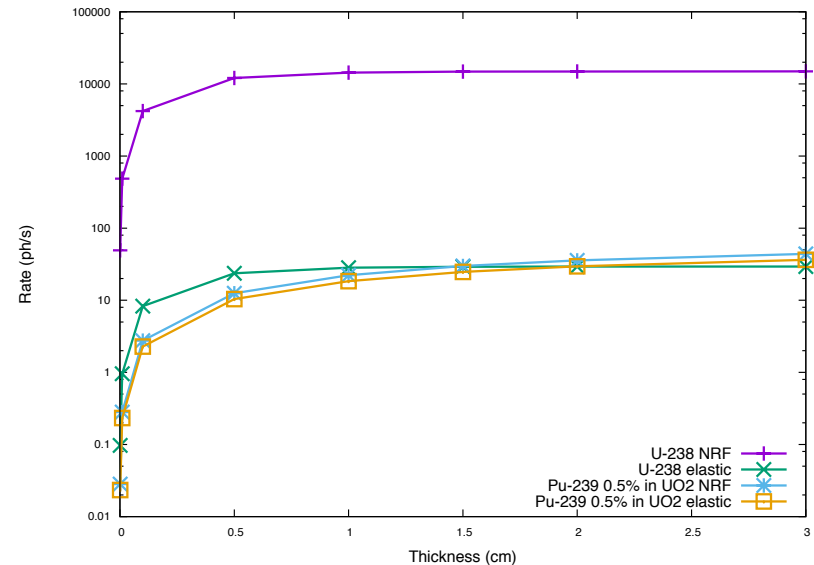

- **511 keV from positrons annihilation**

- segmented detectors to allow for simultaneous detection of many “events”
- thick lead absorbers to remove the background

$$R_{\text{NRF}} \sim 1000 R_{\text{background}} \text{ for small } \sigma \text{ (for a HPGe)}$$

1. Schumacher et al., Nucl. Phys. A 346, 418 (1980).

Delbruck implementation in Geant4

- **Elastic scattering – Rayleigh, Delbruck, Thomson, nuclear resonance excitations**
 - Rayleigh present in Geant4
 - Total elastic cross section obtained from scattering amplitudes calculated using second order S-matrix

$$\left(\frac{d\sigma}{d\Omega}\right)^{exp} = \left(\frac{d\sigma}{d\Omega}\right)^{coh} + \left(\frac{d\sigma}{d\Omega}\right)^{inc} + \left(\frac{d\sigma}{d\Omega}\right)^{NRF}$$

$$\left(\frac{d\sigma}{d\Omega}\right)^{coh} = \frac{1}{2}(|A_{||}|^2 + |A_{\perp}|^2)$$

$$A = A^R + A^D + A^T + A^N$$

M. Schumacher et al. / Delbrück scattering

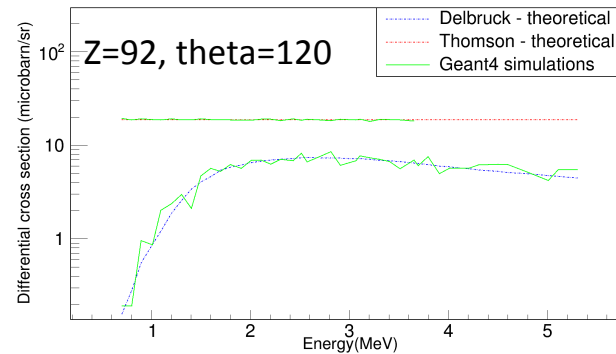
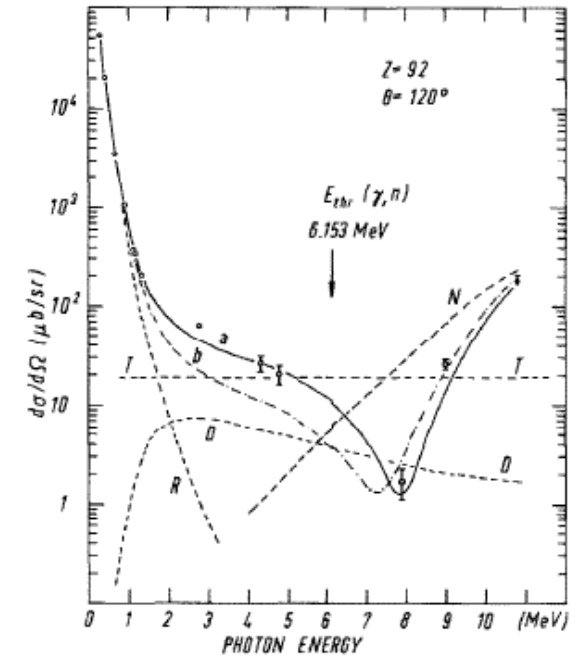

Active interrogation – experimental setups

Experimental methods will be carried out:

- **Scattering NRF** – Standard Method in Nuclear Physics Studies

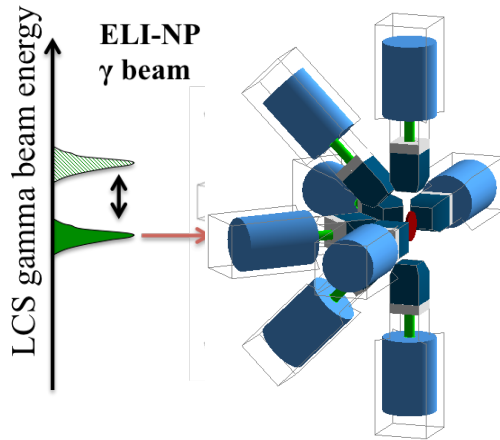

Active interrogation – experimental setups

Experimental methods will be carried out:

- **Scattering NRF** – Standard Method in Nuclear Physics Studies

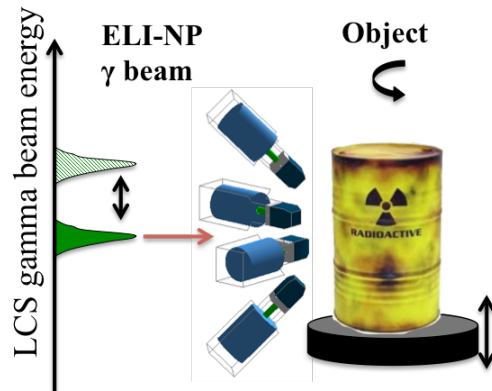

Active interrogation – experimental setups

Experimental methods will be carried out:

- **Scattering NRF** – Standard Method in Nuclear Physics Studies

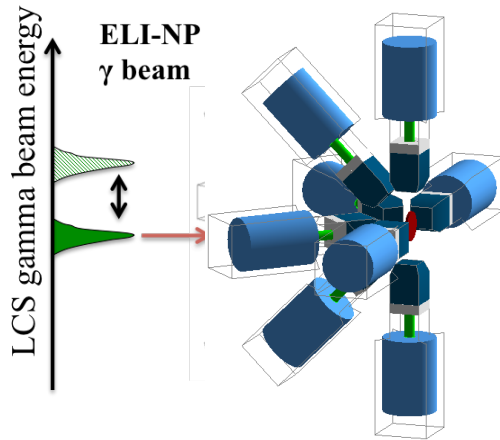

- 8 segmented HPGe
- 2.176 MeV w/ $\Delta E/E = 0.5\%$
- 1×10^9 ph
- 1 cm ^{238}U

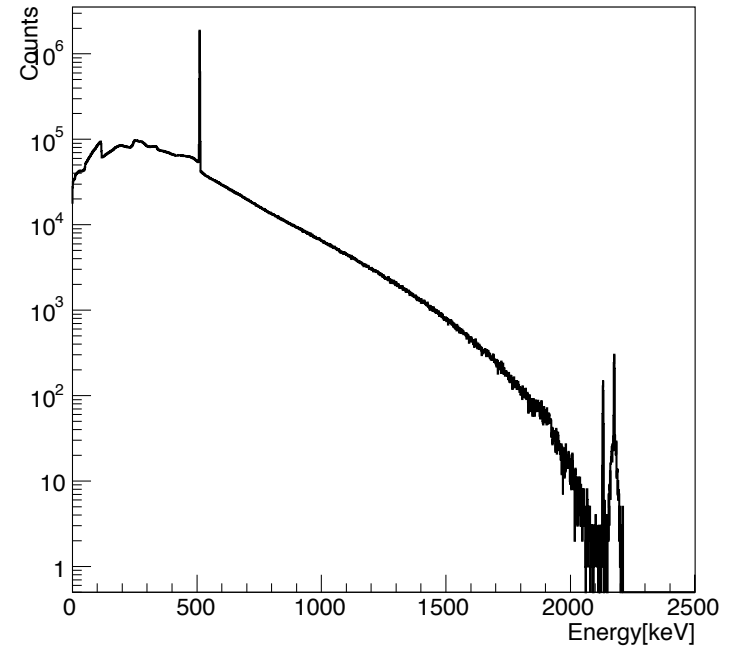

Active interrogation – experimental setups

Experimental methods will be carried out:

- **Scattering NRF** – Standard Method in Nuclear Physics Studies

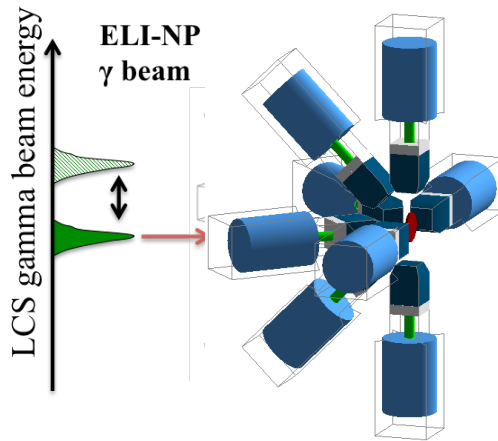

- 8 segmented HPGe
- 2.176 MeV w/ $\Delta E/E = 0.5\%$
- 1×10^9 ph
- 1 cm ^{238}U

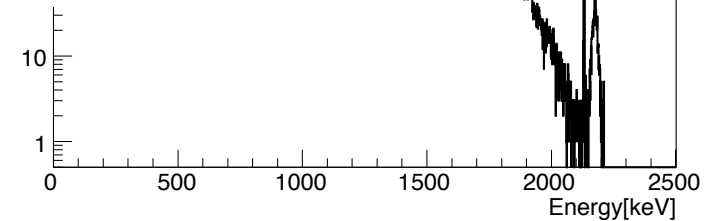
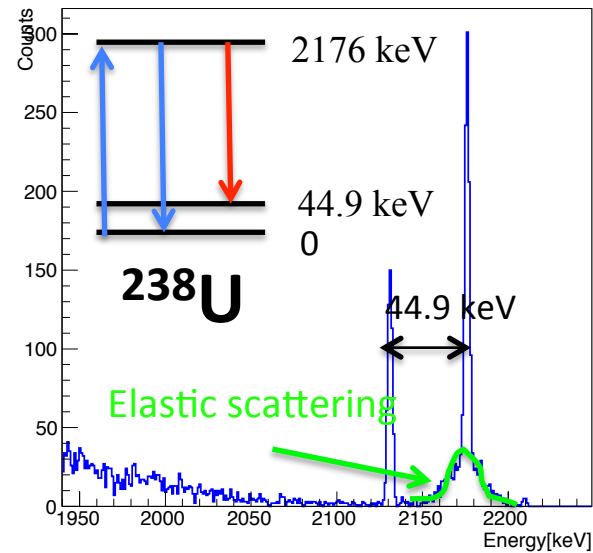

Scattering NRF method

Expected NRF rates for the experimental conditions at ELI-NP were estimated using analytical model¹ and Monte Carlo simulations:

- Small sample sensitivities:

ELI-NP beam
 $\Delta E/E = 0.5 \%$



2.176 MeV

$\varepsilon = 8 \times 0.5 \%$

3×10^8 ph/s

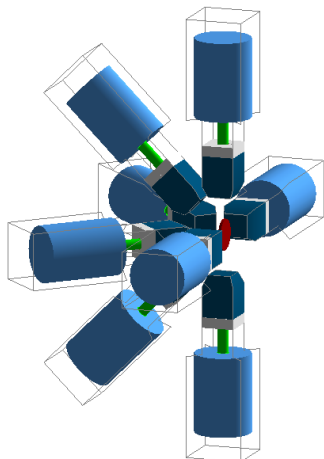

U-238	NRF rate (counts/s)	Time (s) for 3% uncertainty meas.
50 μm – 1.5 mg	4.0*	400
10 μm – 0.3 mg	1.2	1000

* w/ 1 cm Pb to keep total rate per segment < 100 Hz

Scattering NRF method

- Small quantities of isotopes in a matrix:

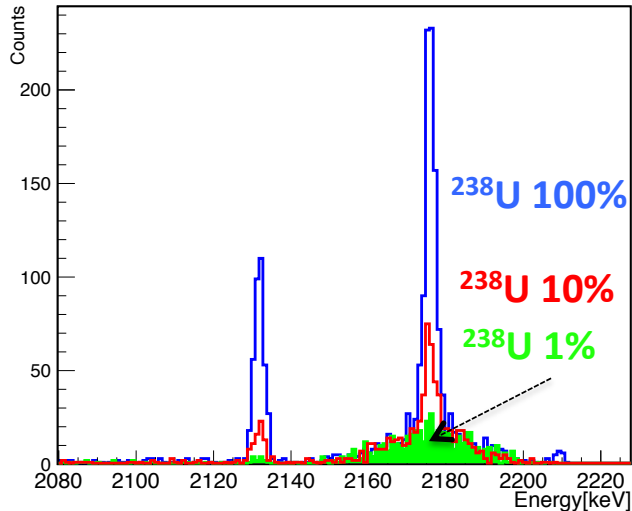

- 1 cm U with different isotopic content
- 2.176 MeV with $\Delta E/E = 0.5\%$
- $\varepsilon = 8 \times 0.5\%$
- 1×10^9 ph

- detection of NRF transition to the ground state

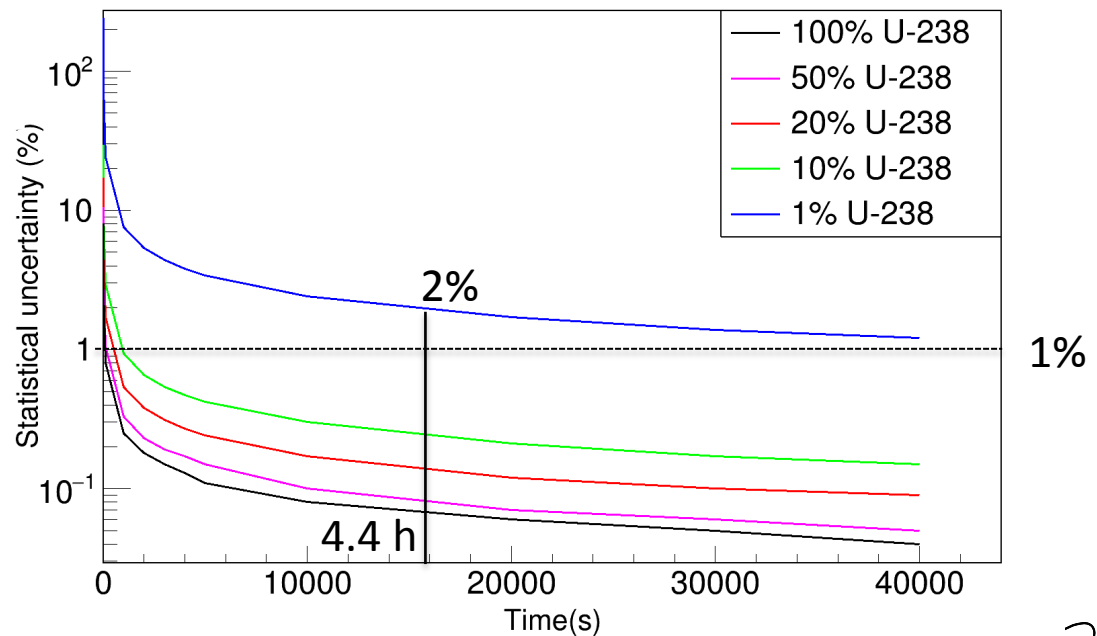
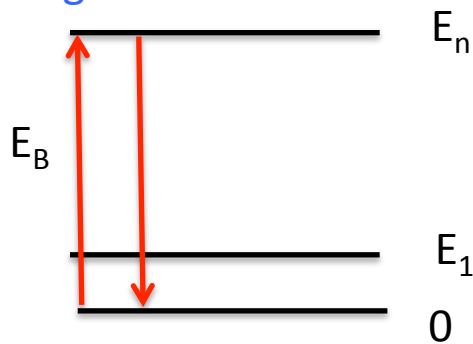

Scattering NRF method

- Small quantities of isotopes in a matrix:

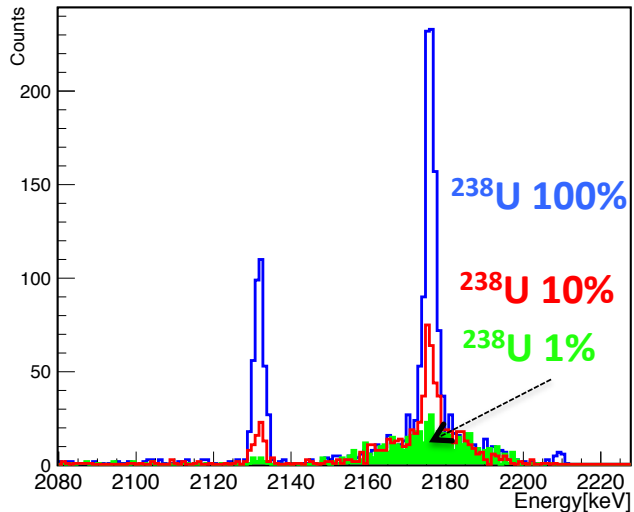

- 1 cm U with different isotopic content
- 2.176 MeV with $\Delta E/E = 0.5\%$
- $\epsilon = 8 \times 0.5\%$
- 1×10^9 ph

- detection of decay branch in NRF transition¹

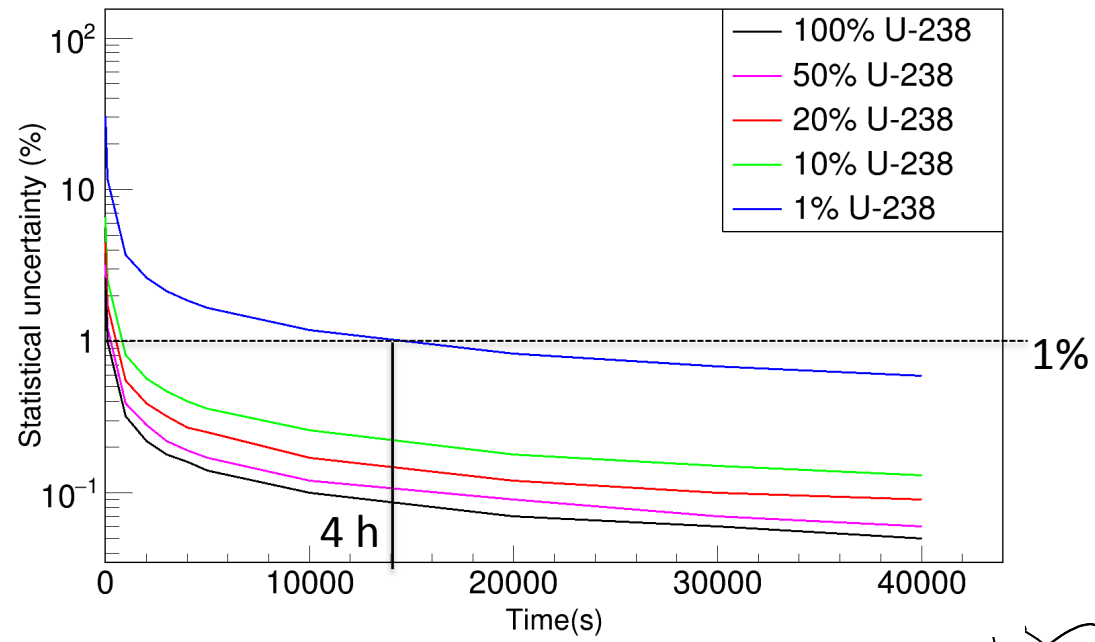
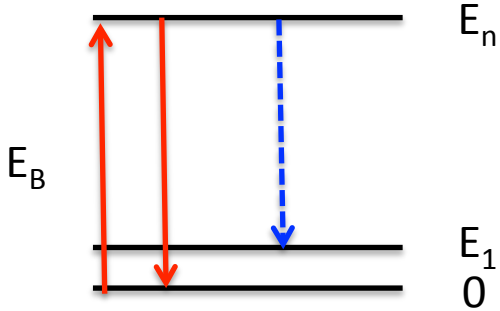

Scattering NRF method

- Small quantities of isotopes in a matrix:

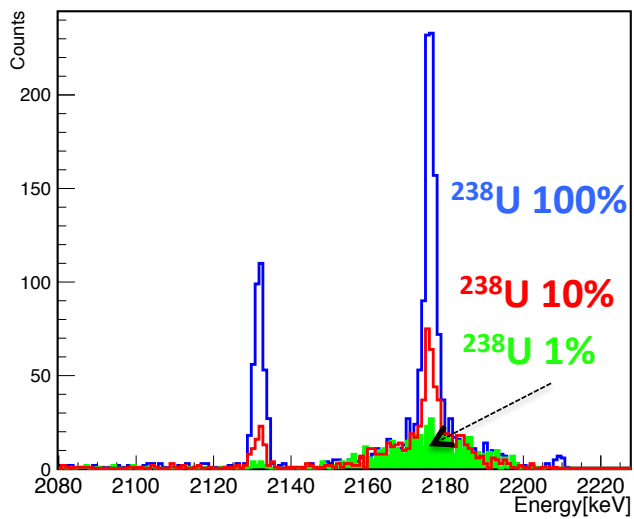

- 1 cm U with different isotopic content
- 2.176 MeV with $\Delta E/E = 0.5\%$
- $\epsilon = 8 \times 0.5\%$
- 1×10^9 ph

$E_1 = 44.9$ keV for U-238
$E_1 = 46.2$ keV for U-235
$E_1 = 42.8$ keV for Pu-240
$E_1 = 7.9$ keV for Pu-239

- detection of decay branch in NRF transition¹

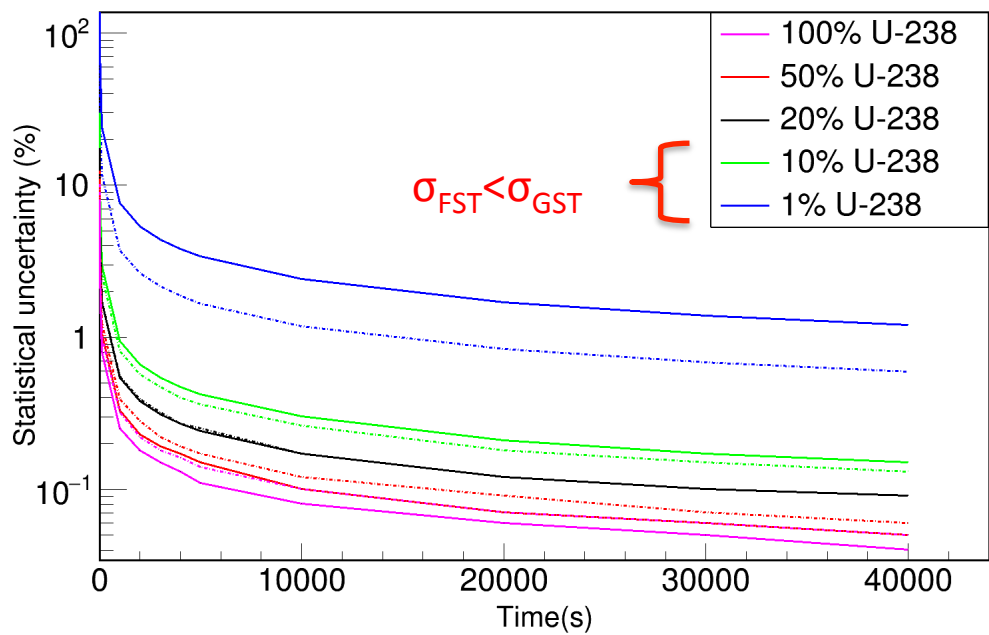
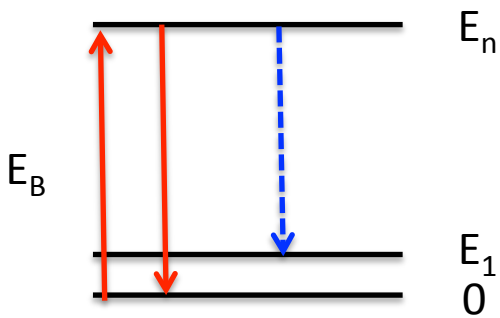

Active interrogation – experimental setups

Experimental methods will be carried out:

- **Self-absorption/Transmission NRF** (proposed by Bertozzi¹ in 2005)

Main interest in SNM control management

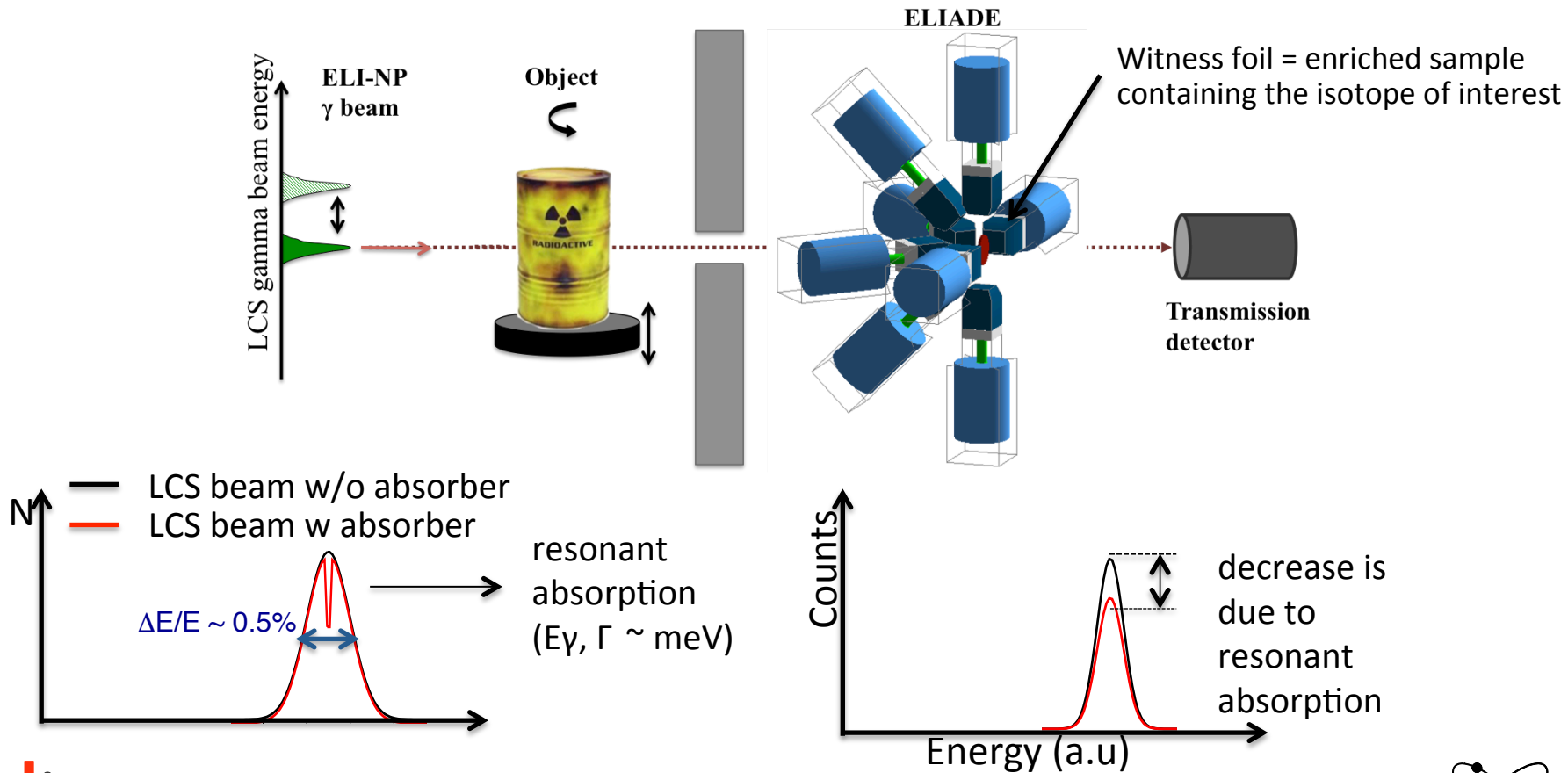

Active interrogation – experimental setups

Two experimental methods will be carried out:

- **Self-absorption/Transmission NRF** (proposed by Bertozzi¹ in 2005)

Main interest in SNM control management

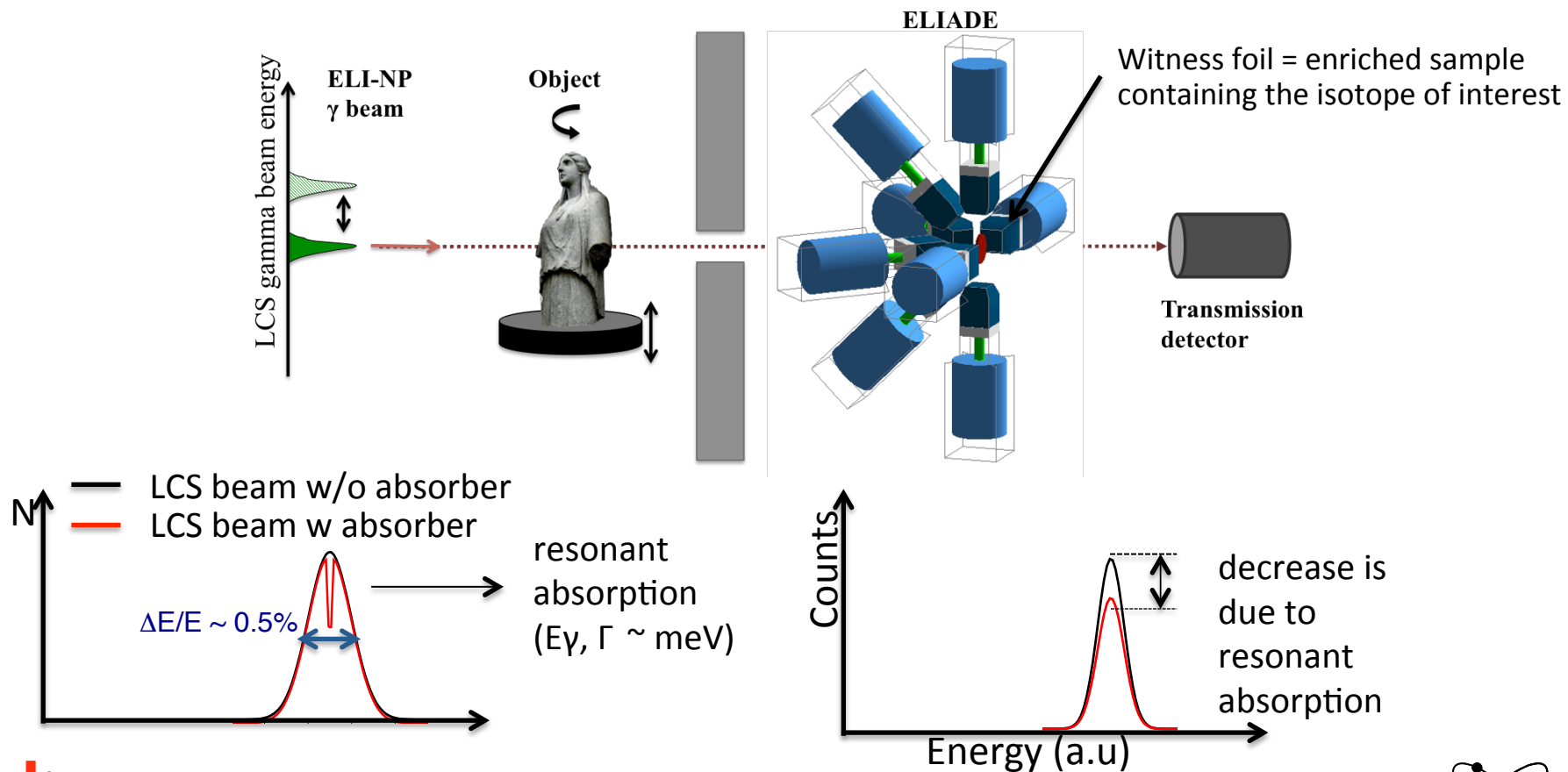

Transmission NRF setup

NRF used in combination with radiography and tomography at ELI-NP can produce isotope-specific maps at single resonance level

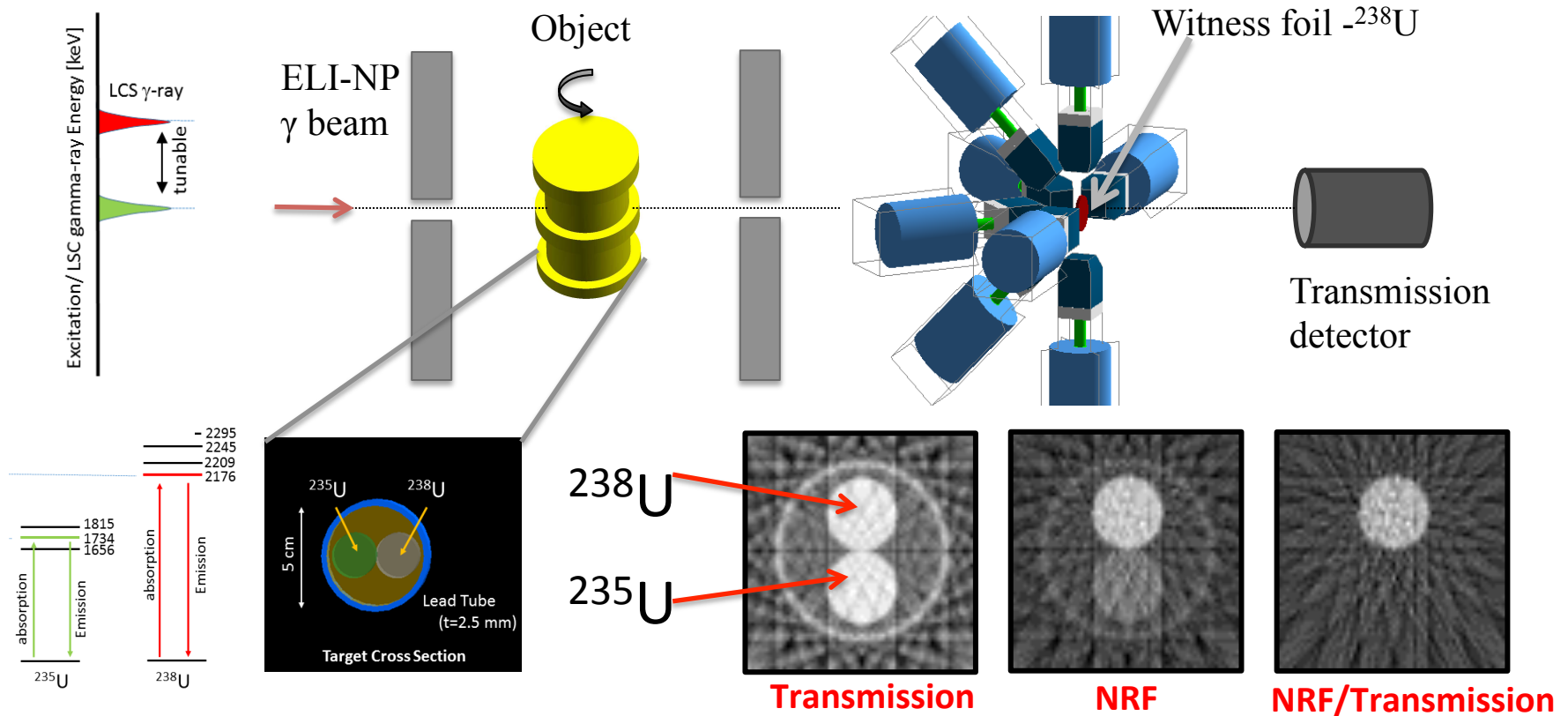

Distinguish ^{238}U from ^{235}U by tuning the gamma beam energy to the NRF transition energy of ^{238}U ($E_\gamma = 2.176$ MeV) and using 5 mm of ^{238}U for a witness foil (21 h at ELI-NP)

Gamma-beam radiography and tomography

Image large and/or complex objects with high resolution: 2D and 3D imaging

- High-energy photons -> penetrate large objects (MeV photons are the best).
- Monochromatic photon beam -> linear attenuation coefficient determination

Non-destructive analyses:

- ❖ Automotive engines and their components
- ❖ Concrete structures, carbon-metal composites
- ❖ Sinterization, weldings, phase distribution
- ❖ Work of arts, ancient artifacts

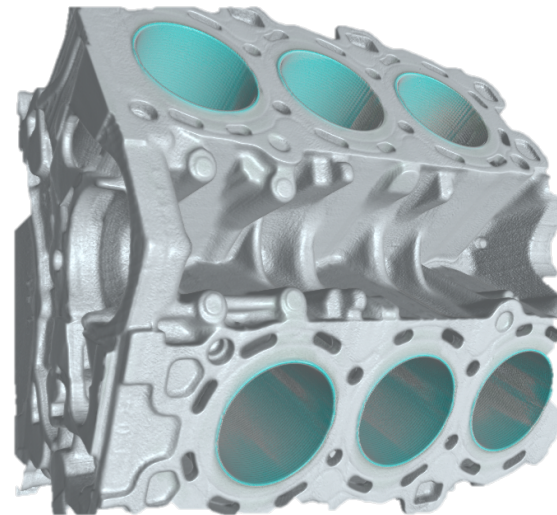

Courtesy Varian Inspections

LCS gamma beam industrial CT – previous experiments

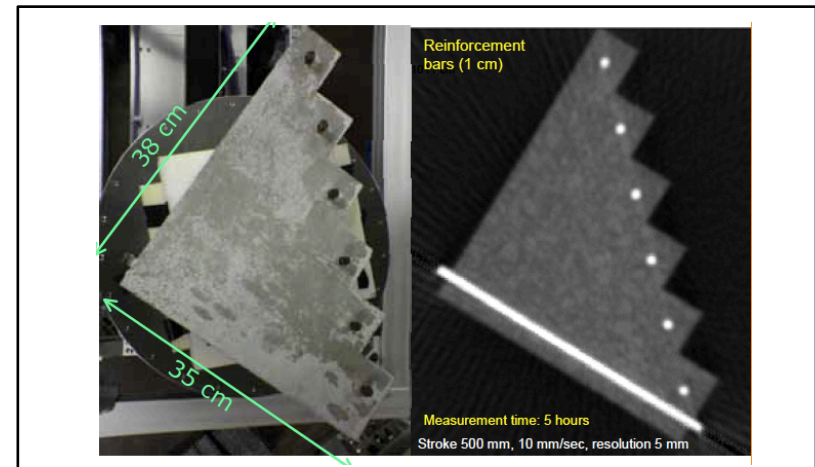
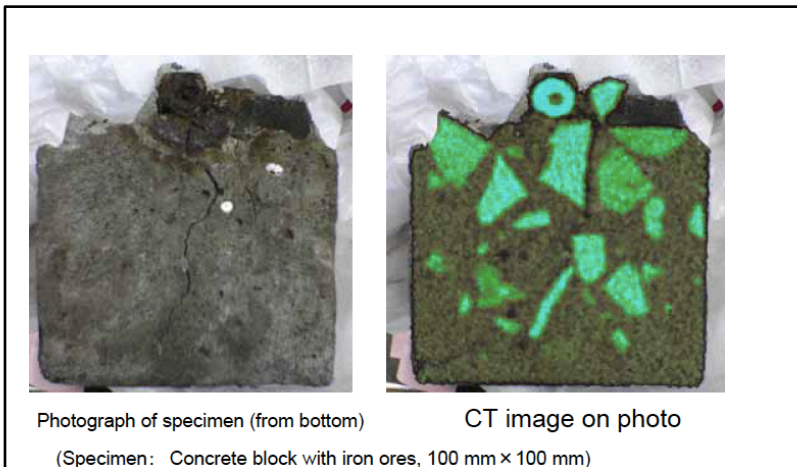
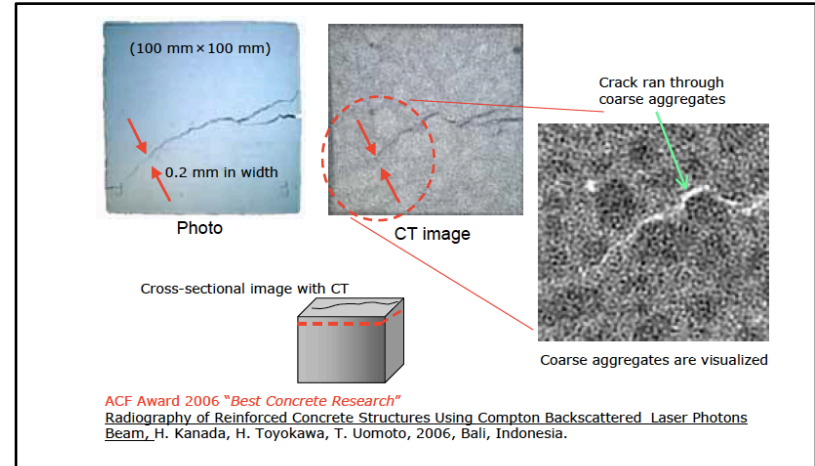
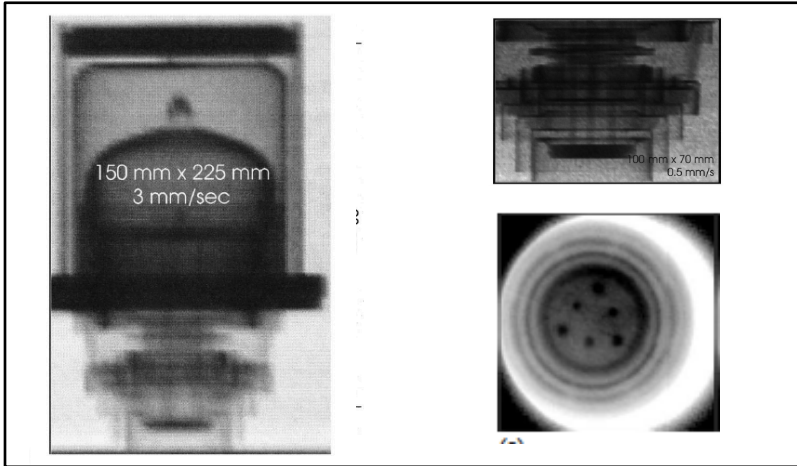

Gamma-beam radiography and tomography at ELI-NP

Image large and/or complex objects with high resolution: 2D and 3D imaging

- Two experimental setups: pencil beam CT and cone-beam CT
- Target resolution of 0.1 – 1 mm in objects up to 150 kg

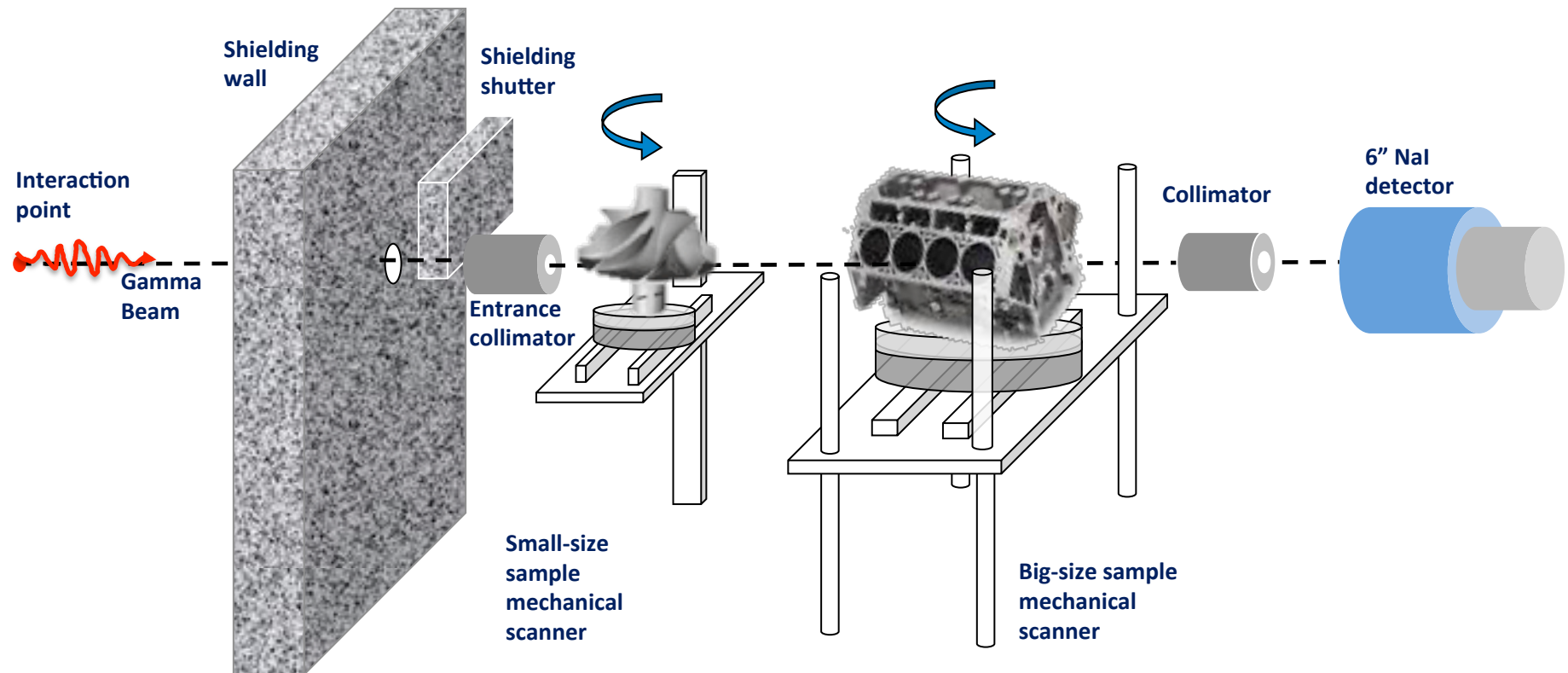

Courtesy of M. Iovea, AccentPro2000

Gamma-beam radiography and tomography at ELI-NP

Image large and/or complex objects with high resolution: 2D and 3D imaging

- Two experimental setups: pencil beam CT and cone-beam CT
- Target resolution of 0.1 – 1 mm in objects up to 150 kg

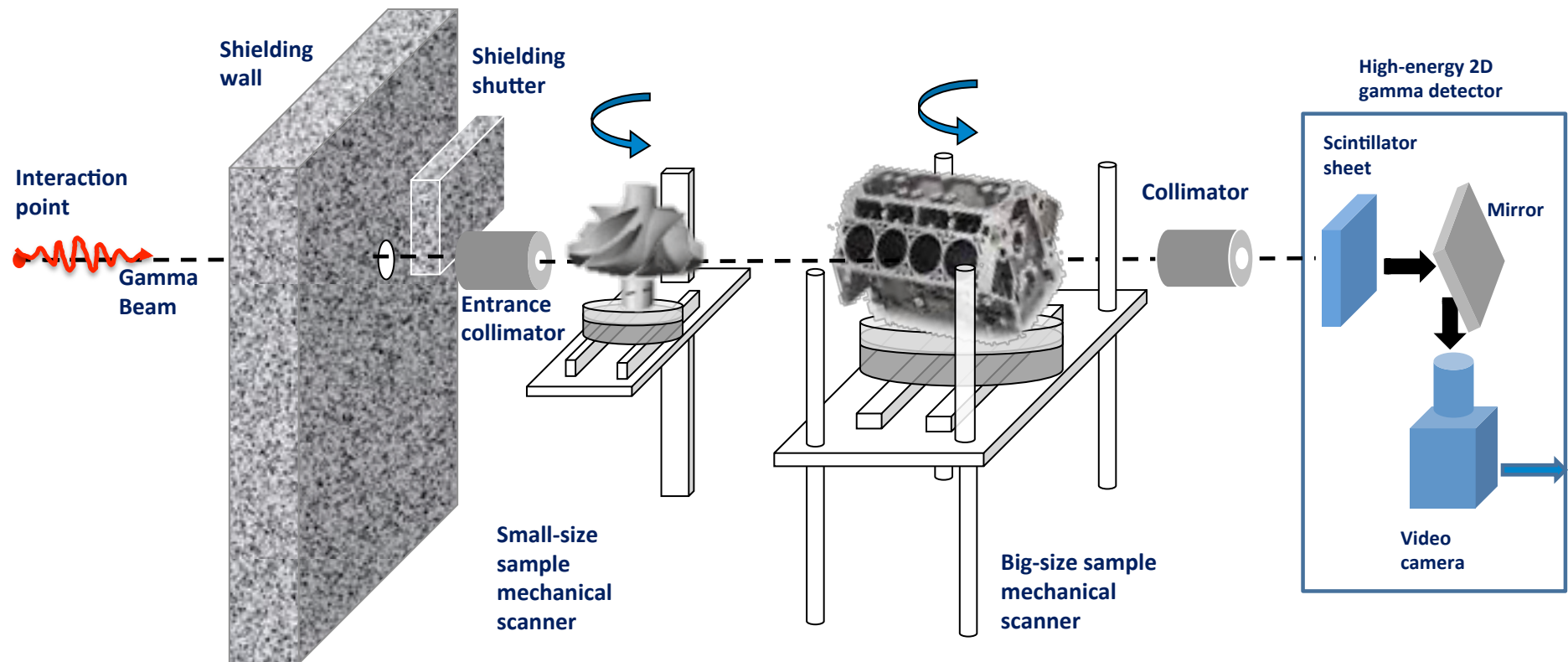

Courtesy of M. Iovea, AccentPro2000

Industrial radiography and tomography at ELI-NP

- Performance estimated based on analytical model and GEANT4 simulations¹
 - Pencil-beam setup - image objects up to 40 cm of Al with 0.7 mm resolution with 1s/exposure - higher resolution in smaller objects or lower Z
 - Cone-beam and fan-beam CT simulations:

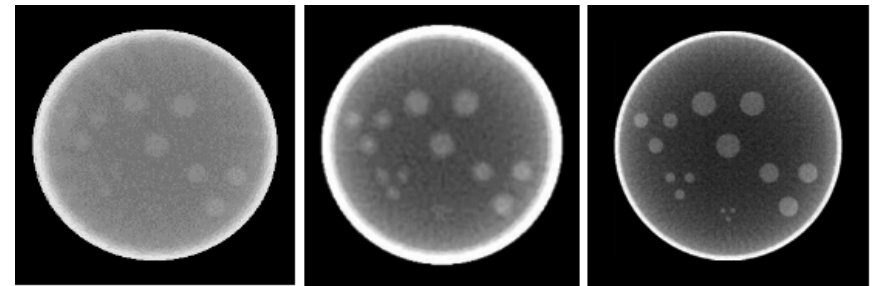
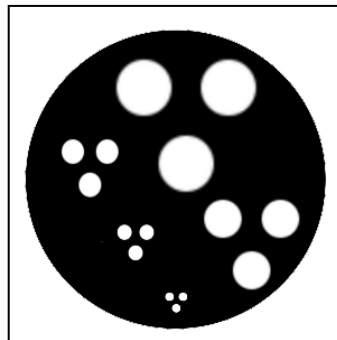
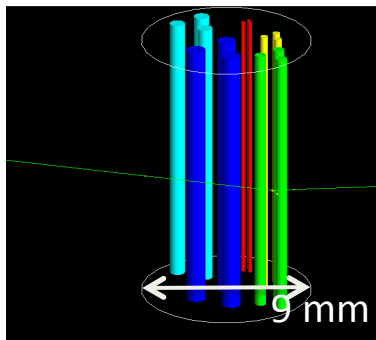

FBP 33 projections

FBP 66 projections

FBP 100 projections

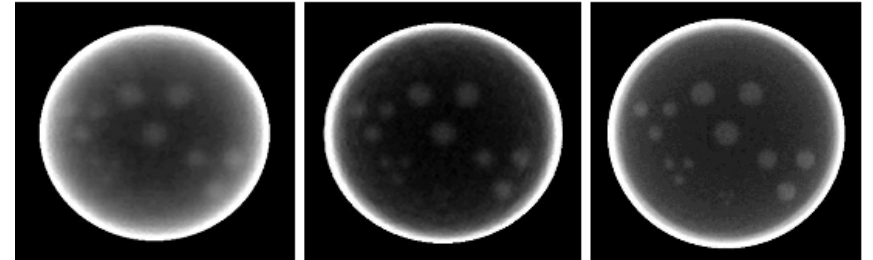

SART 33 projections

SART 66 projections

SART 100 projections

- 0.2 mm to 1 mm holes and spacing
- Fan beam: 2.5×10^7 ph/s, 1 mrad, 1 MeV
- 1 proj/s

Nr of projections	Resolution limit
33	0.6 mm
66	0.4 mm
100	0.2 mm

¹Rom. Rep. Phys. 68, S799-S845 (2016)

Summary

❑ **Gamma Beam System based on Inverse Compton Scattering:** high intensity, high spectral density, small bandwidth, tunable energy gamma beams



- ❑ Elemental, structural and isotopic composition analyses of materials
- Nuclear Resonance Fluorescence – perfect challenge for ELI-NP
 - Gamma ray attenuation – high resolution imaging in large objects

Gamma beams system status

- 2016: Completion of buildings
- 2017: Equipment for producing 1 MeV and 3 MeV gamma beams is being delivered to the site > July 2017 (stage I and II)
- Assembly and testing of the low-energy stage: $E_\gamma < 3.5$ MeV
 - 2018
- High-energy stage: $E_\gamma < 19.5$ MeV
 - end of 2018



Project co-financed by the European Regional Development Fund through the Competitiveness Operational Programme
“Investing in Sustainable Development”

**Extreme Light Infrastructure-Nuclear Physics
(ELI-NP) - Phase II**

ELI-NP

Violeta Iancu
Gabriel Suliman
Gabriel V. Turturica
Calin A. Ur
Dimitre L. Balabanski

Accent PRO 2000

Romania
Mihai Iovea
Edward

***The Institute for Advanced
Energy, Kyoto University***

Japan
Izuru Daito
Hideaki Ohgaki

Louis Giesen

THANK YOU



Gamma beam time structure

Time structure of the beam

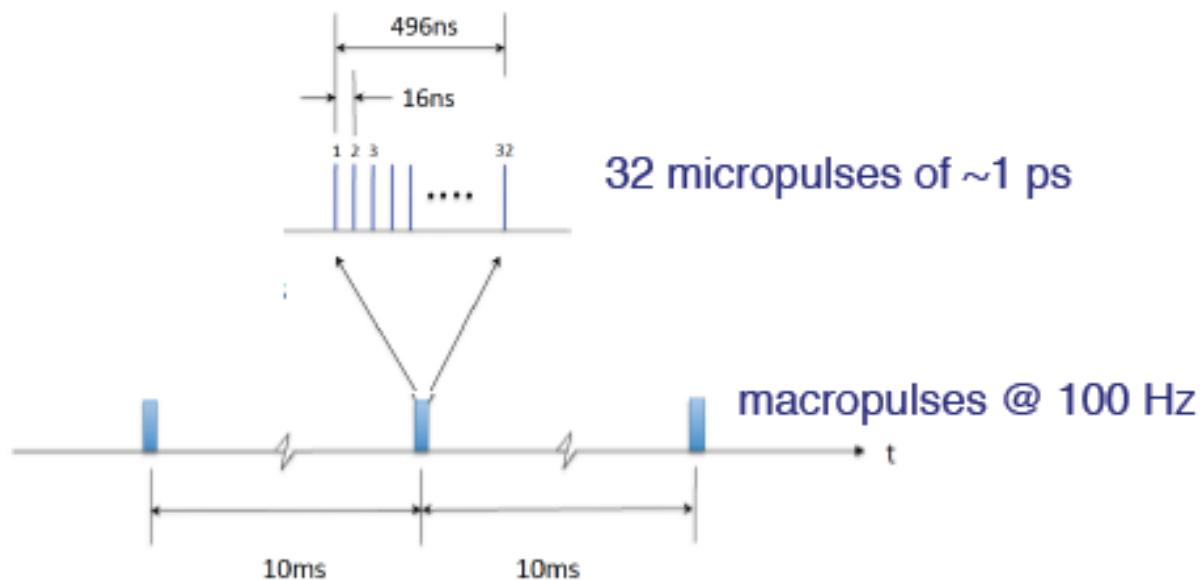

ELI-NP Array of Detectors: ELIADE

GEANT4 Monte Carlo simulations for the array efficiency, P/T ratio and background mitigation

- segmented detectors to allow for simultaneous detection of many “events”
- thick lead absorbers to remove the background

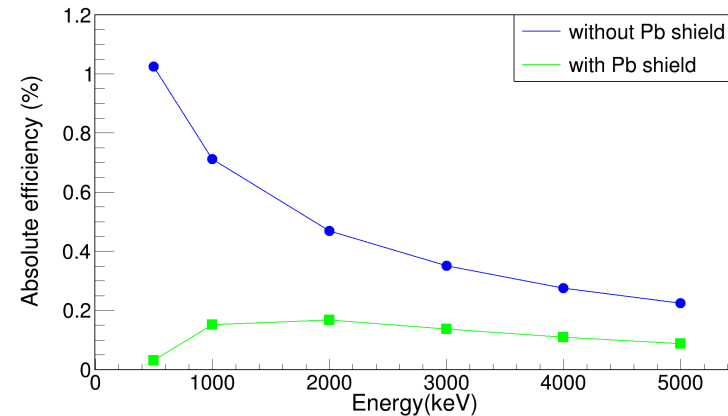
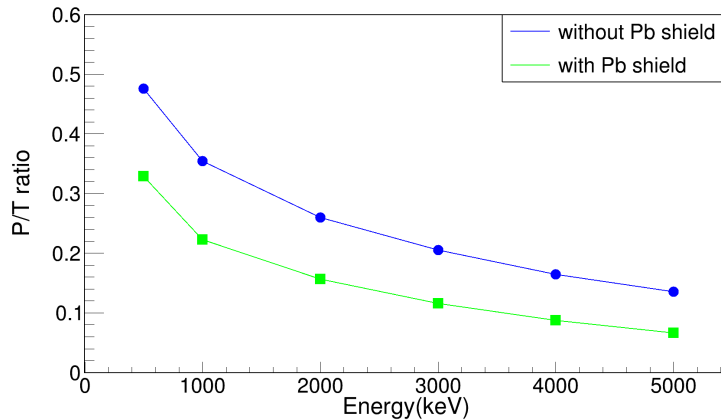
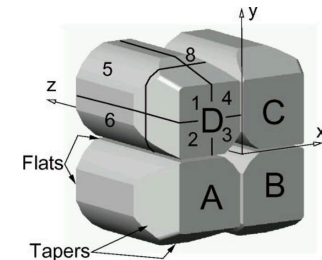

Efficiency curves for a single clover detector with and without a 2 cm lead shield.